

GRÜEZI!

Thank you for purchasing our **Swiss-made product**, crafted with skilled craftsmanship by our Schaffner team.

BODENSEE

MANUFACTURED IN SWITZERLAND.

10005 Bodensee Glasfaser-Tisch Ø75 klappbar
10003 Bodensee Glasfaser-Tisch Ø100 klappbar
10001 Bodensee Glasfaser-Tisch Ø120 klappbar

14003 Bodensee Glasfaser-Tisch 70×70 klappbar
14022 Bodensee Glasfaser-Tisch 80×80 klappbar

10040 Bodensee Glasfaser-Stehtisch Ø75/110 klappbar





ASSEMBLY VIDEO



ALL PARTS SUPPLIED

- 1 × table top
- 1 × column
- 1 × star-shaped foot
- 1 × clamping bracket

- 4 × notched nails
- 4 × notched nail holders
- 5 × floor levelling screws

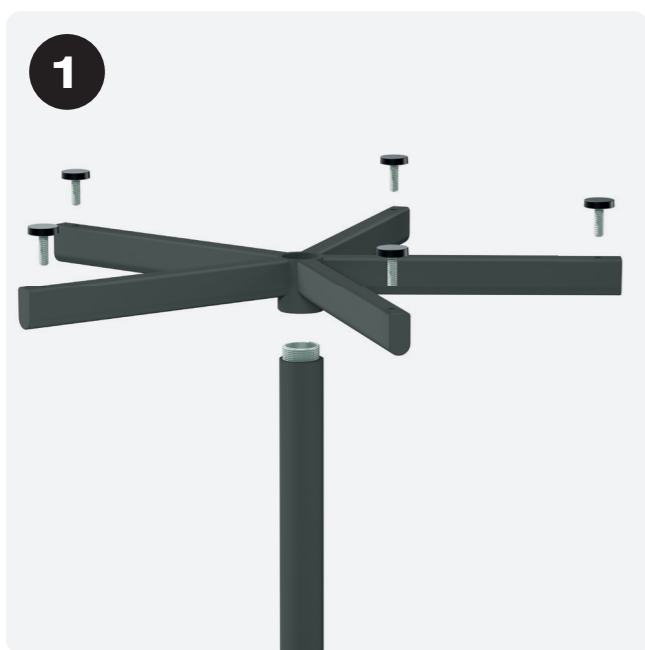

1 Screw the star-shaped foot to the column and affix 5 floor levelling screws to the feet.



2 Place the pedestal on the table top so that the pedestal supports are between the struts. Then, secure in place on both sides with a notched nail and a notched nail holder.



3 Place the two clamping brackets outside the struts and secure on both sides with a notched nail and a notched nail holder.

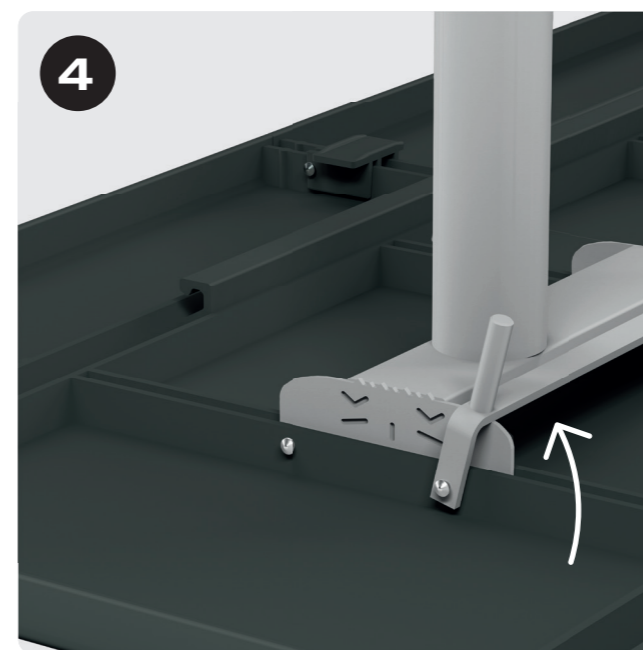

4 Secure the table top with the two clamping brackets.

swiss made 

We've been making our garden furniture at our factory in Thurgau for over 70 years. With decades of experience, skilful craftsmanship and attention to detail, we manufacture durable garden furniture.

SAFETY

Please read these instructions before installing and using the product.

- Place a piece of cardboard underneath to protect the table top.
- Make sure that nobody – especially children – puts their fingers into moving or closing mechanisms. This product is not a toy.
- Only install and use it on a firm, level surface
- If there are signs of damage (e.g. loose screws, bent parts), we recommend contacting the retailer.
- Use original Schaffner spare parts to ensure proper functioning.

WARRANTY

Our products are constantly being improved and refined.
We reserve the right to make changes to their design and technology.
If you would like to make a warranty claim, please contact your retailer.

CARE INSTRUCTIONS



ORIGINAL SPARE PARTS



REPAIR SERVICE

